

## IDENTIFICATION OF FUSES

Fuses have identifications printed on them. The printing on the fuse will identify the physical size, the type of fuse, and the fuse ratings.

There are four different systems used to identify fuses. The systems are the old military designation, the new military designation, the old commercial designation, and the new commercial designation. All four systems are presented here, so you will be able to identify a fuse no matter which designation is printed on the fuse.

You may have to replace an open fuse that is identified by one system with a good fuse that is identified by another system. The designation systems are fairly simple to understand and cross-reference once you are familiar with them.

### OLD MILITARY DESIGNATION

Figure 2-8 shows a fuse with the old military designation. The tables in the lower part of the figure show the voltage and current codes used in this system. The upper portion of the figure is the explanation of the old military designation. The numbers and letters in parentheses are the coding for the fuse shown in figure 2-8.

Figure 2-8. - Old type military fuse designation.

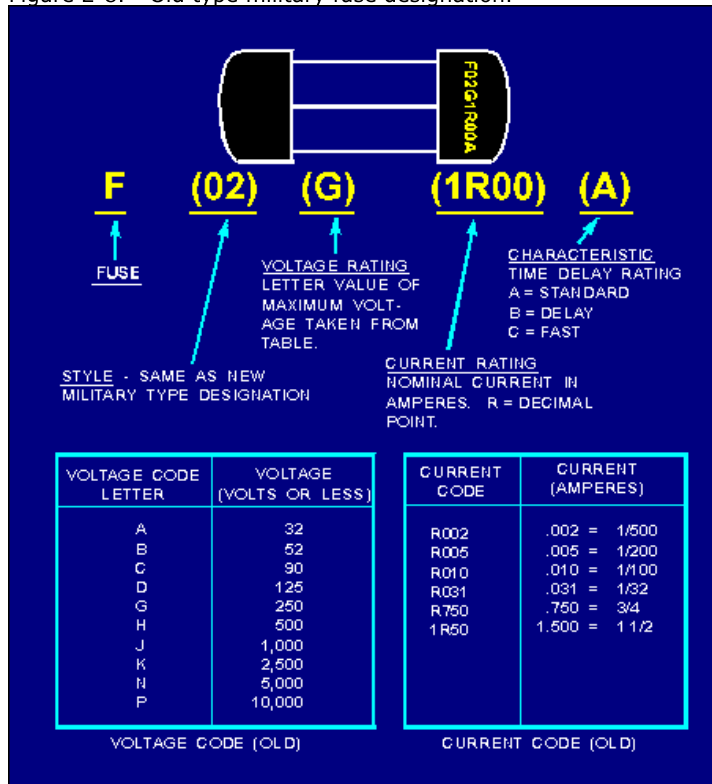

The old military designation always starts with "F," which stands for fuse. Next, the set of numbers (02) indicates the style.

Style means the construction and dimensions (size) of the fuse. Following the style is a letter that represents the voltage rating of the fuse (G).

The voltage code table in figure 2-8 shows each voltage rating letter and its meaning in volts. In the example shown, the voltage ratings is G, which means the fuse should be used in a circuit where the voltage is 250 volts or less. After this is a set of three numbers and the letter "R," which represent the current rating of the fuse. The "R" indicates the decimal point. In the example shown, the current rating is 1R00 or 1.00 ampere. Some other examples of the current rating are shown in the current code table of figure 2-8. The final letter in the old military designation (A) indicates the time delay rating of the fuse.

While the old military designation is still found on some fuses, the voltage and current ratings must be "translated," since they use letters to represent numerical values. The military developed the new military designations to make fuse identification easier.

#### NEW MILITARY DESIGNATION

Figure 2-9 is an example of a fuse coded in the new military designation. The fuse identified in the example in figure 2-9 is the same type as the fuse used as an example in figure 2-8.

Figure 2-9. - New type military fuse designation.

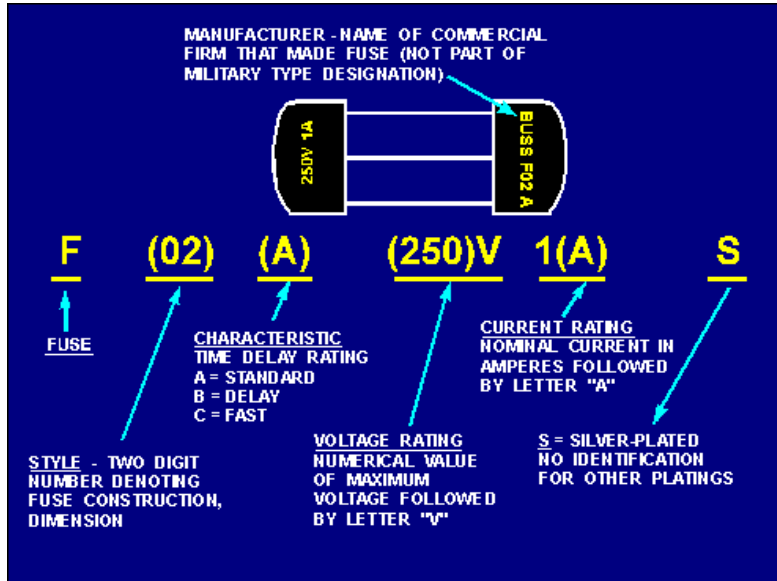

The new military designation always start with the letter "F," which stands for fuse. The set of numbers (02) next to this indicates the style. The style numbers are identical to the ones used in the old military designation and indicate the construction and dimensions of the fuse. Following the style designation is a single letter (A) that indicates the time delay rating of the fuse. This is the same time delay rating code as indicated in the old military designation, but the position of this letter in the coding is changed to avoid confusing the "A" for standard time delay with the "A" for ampere. Following the time delay rating is the voltage rating of the fuse (250) V. In the old military designation, a letter was used to indicate the voltage rating. In the new military designation, the voltage is indicated by numbers followed by a "V," which stands for volts or less. After the voltage rating, the current rating is given by numbers followed by the letter "A." The current rating may be a whole number (1A), a fraction (1/500 A), a whole number and a fraction (1 1/2A), a decimal (0.250A), or a whole number and a decimal (1.50A). If the ferrules of the fuse are silver-plated, the current rating will be followed by the letter "S." If any other plating is used, the current rating will be the last part of the fuse identification.

As you can see, the new military designation is much easier to understand than the old military designation.

You may find a fuse coded in one of the commercial designations.

The commercial designations are fairly easy to understand and figure 2-10 shows the old and new commercial designations for the same type of fuse that was used in figures 2-8 and 2-9.

Figure 2-10. - Commercial designations for fuses:

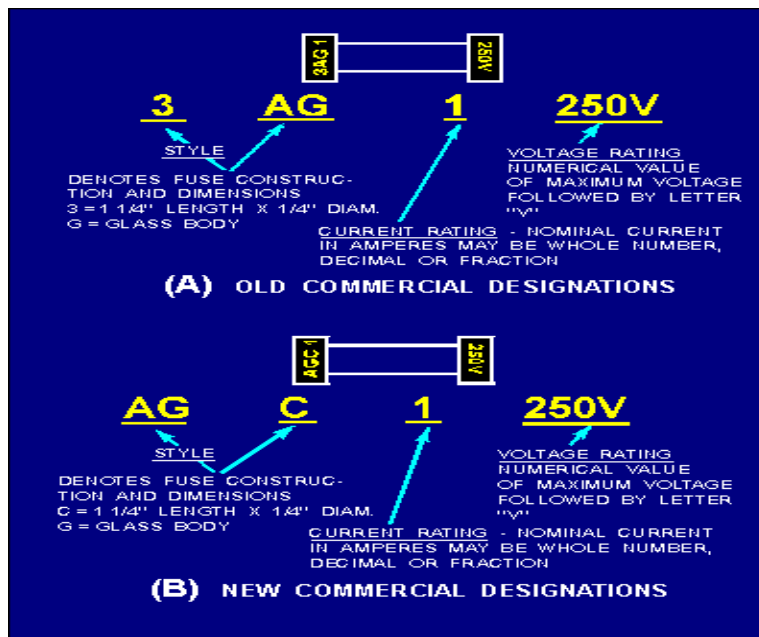

#### OLD COMMERCIAL DESIGNATION

Figure 2-10, view A, shows the old commercial designation for a fuse. The first part of the designation is a combination of letters and numbers (three in all) that indicates the style and time delay characteristics. This part of the designation (3AG) is the information contained in the style and time delay rating portions of military designations.

In the example shown, the code 3AG represents the same information as the underlined portions of F02 G 1R00 A from figure 2-8 (Old Military Designation) and F02A 250VIAS from figure 2-9 (New Military Designation). The only way to know the time delay rating of this fuse is to look it up in the manufacturer's catalog or in a cross-reference listing to find the military designation. The catalog will tell you the physical size, the material from which the fuse is constructed, and the time delay rating of the fuse. A 3AG fuse is a glass-bodied fuse, 1/4 inch X 1 1/4 inches (6.35 millimeters X 31.8 millimeters) and has a standard time delay rating.

Following the style designation is a number that is the current rating of the fuse (1). This could be a whole number, a fraction, a whole number and a fraction, a decimal, or a whole number and a decimal. Following the current rating is the voltage rating; which, in turn, is followed by the letter "V," which stands for volts or less (250V).

#### NEW COMMERCIAL DESIGNATION

Figure 2-10, view B, shows the new commercial designation for fuses. It is the same as the old commercial designation except for the style portion of the coding. In the old commercial system, the style was a combination of letters and numbers. In the new commercial system, only letters are used. In the example shown, 3AG in the old system becomes AGC in the new system. Since "C" is the third letter of the alphabet, it is used instead of the "3" used in the old system. Once again, the only way to find out the time delay rating is to look up this coding in the manufacturer's catalog or to use a cross-reference listing. The remainder of the new commercial designation is exactly the same as the old commercial designation.

The basic elements of a traditional fuse are a fusible link or links encapsulated in a tube or case and connected to contact terminals. The modern fuse can take many forms and use many different techniques to interrupt over currents. When potentially damaging over currents occur, the link will melt very quickly, protecting conductors and circuit components.

## FUSES

Fuses serve two main purposes:

1. To protect components and equipment from damage caused by over currents.
2. To isolate sub-systems from the main system once fault or over current has occurred.

## OVER CURRENTS

Over currents exist when the normal load for a circuit is exceeded. It can be either an *overload* or *short circuit*.

- a.) An *overload* is any current flowing within the normal circuit path that is higher than the circuit's normal full load current.
- b.) A *short circuit* is an over current which greatly exceeds the normal full load current of the circuit. Also, as the name infers, a short circuit leaves the normal current carrying path of the circuit and takes a *short cut* around the load and back to the power source.

When the manufacturer of a device wants to protect from an over current, the fuse selected must interrupt the over current, limit the energy let through, and withstand the voltage across the fuse during arcing. Also, the following items must be considered:

1. Voltage rating
2. Full load currents (amperes)
3. Available short circuit current
4. In-rush characteristics
5. Characteristics of equipment or components to be protected
6. Ambient temperature
7. System frequency
8. Wet or dry location

## FUSE REPLACEMENT

The proper replacement fuse needed for a particular application can be determined more simply by keeping the following in mind:

1. Fuse shape and physical size -

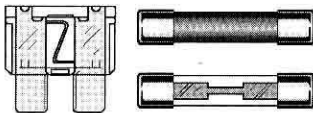

2. Voltage Rating - The maximum value of the system voltage in which a fuse can be used, yet safely interrupt an overcurrent. Exceeding the voltage rating of a fuse impairs its ability to clear an overload or short circuit safely. The voltage rating of the fuse must be greater than or equal to the circuit voltage. For example:

CIRCUIT VOLTAGE	MAXIMUM FUSE VOLTAGE
0-32	32 volts
0-125	125 volts
0-250	250 volts

FUSES . PDF

3. Current Rating (ampere rating) - This is the current carrying capacity of a fuse. When a fuse is subjected to a current above its ampere rating, it will open the circuit after a predetermined period of time. Each fuse is marked with an ampere rating. Typically, it is marked with the product catalog symbol followed by the amperage. For example, AGC-15 denotes a 15 Ampere fuse.

4. Fuse Type:

- a.) Time Delay Fuse: a fuse with a built in delay that allows temporary and harmless inrush currents to pass without opening, but is also designed to open on sustained overloads and short circuits. Time delay fuses are ideal for circuits with a transient surge or power-on inrush, such as for use in motors, transformers, or incandescent lamps.
- b.) Dual Element Fuse: a fuse with a special design that utilizes two individual elements in series inside the fuse tube. One element, the spring actuated trigger assembly, operates on overloads up to 5-6 times the fuse current rating. The other element, the short circuit section, operates on short circuits up to their *interrupting rating*. The *interrupting rating* defines a fuses ability to safely interrupt and clear short circuits.
- c.) Non Time Delay: these fuses have no intentional built-in time-delay and are used in circuits without transient in-rush currents.

## FUSE TYPES

The illustrations below show the different types of components used to protect automotive electrical circuits:

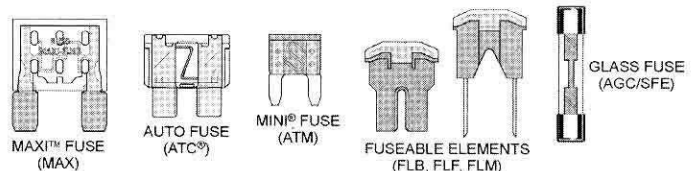

### FUSE REPLACEMENT GUIDELINES

(When replacing a fuse, follow these guidelines)

- Positively identify the exact type of fuse.
- Use a replacement fuse which has the exact amp rating as the original.
- If replacement does not restore current to the amp circuit, there may be:
  - 1.) A short in the circuit
  - 2.) A component which provides a secondary circuit protection (such as a fusible link) needs to be replaced. use the proper diagnostic equipment along with the circuit wiring diagram to find the problem and make the repair.